

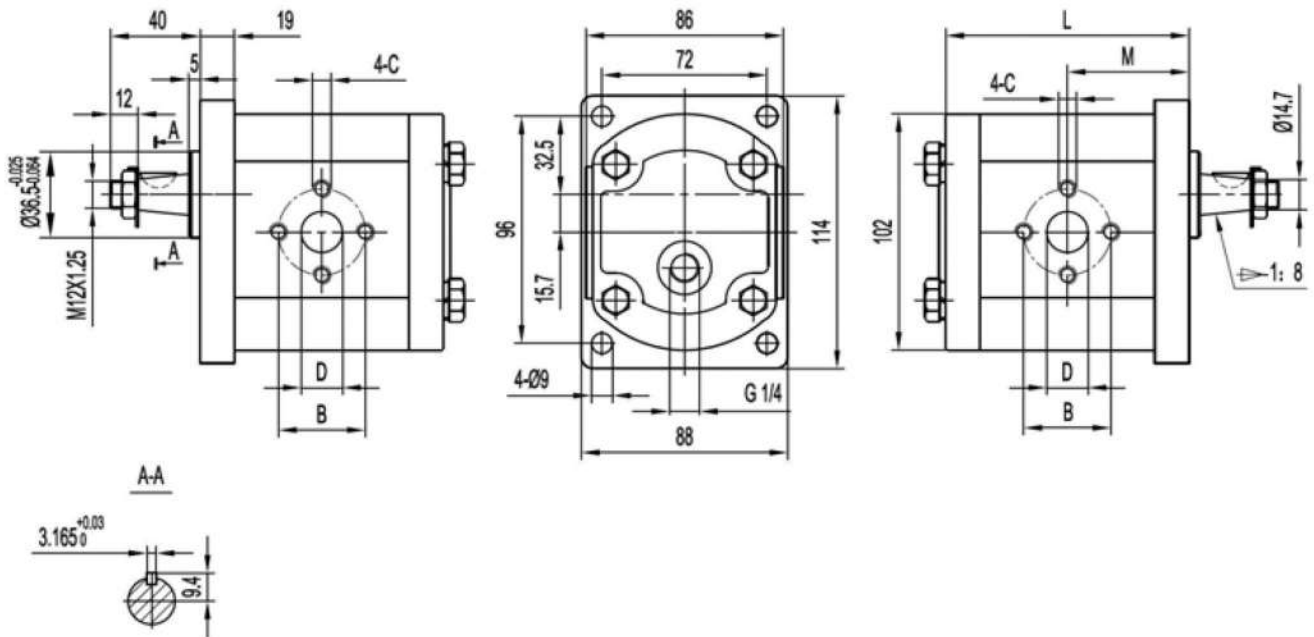

TECHNICAL DATA

PRODUCT	DISPLACEMENT	MAX. PRESSURE (bar)			SPEED (r/min)	
	(cm ³)	P1	P2	P3	MAX	MIN
KM2R6G	6	270	285	300	4000	600
KM2R10G	10	270	285	300	3000	500
KM2R14G	12	250	265	280	3000	500
KM2R16G	14	250	265	280	3000	500
KM2R20G	16	250	265	280	3000	500



TECHNICAL DATA

PRODUCT	DIMENSIONS				
	M (mm)	L (mm)	B (mm)	D (mm)	H
KM2 R6G	46	96	30	13	M6
KM2R10G	49.3	102.6	40	20	M8
KM2R14G	52.7	109.3	40	20	M8
KM2R16G	54.4	112.7	40	20	M8
KM2R20G	57.7	119.3	40	20	M8